

SURFXTM

6400 W. 105th St.
Bloomington, MN 55438

SURFXTM

winter 2001

Our First
Complete Bike!

Cross-Check™

Just in time for 'cross season, as if that really matters - **Surly Cross-Check™** complete bikes!

At the core of our very first complete is the fab new Cross-Check™ frame and fork. Having made only minor changes on the frameset for this fall, we once again bow in honor and respect to the rich European tradition of cyclo-cross racing. But leave the overpriced, single-purpose, disposably-light bikes lacking of tire clearance to be made by some other manufacturer.

When you spend your hard-earned cash on a Cross-Check™, you'll get a very aggressive, multi-purpose, off-road worthy 700c-wheeled steed that is cross-raceable, rideable, tour-able, commute-able, and downright single-trackable. By now you know **there is no free lunch**, but once you ride a Cross-Check™ you'll realize that it is possible to have a reasonable compromise between hard-core geometry and comfort, between weight and durability, and between price, features and quality.

Our parts specification is exactly what you'd expect from Surly™ - Every component was chosen with value, durability, versatility, and fit in mind. We won't bother with name-dropping now (consult the chart below), but we think you'll agree: The stuff we've spec'd simply works, works well, and is intended to be practical and serviceable for years to come.

The Cross-Check™ rides like a champ out of the box, but if you're like us, you'll want to do a little experimenting. That's why we went to great lengths to ensure maximum compatibility with all available tire widths, brands of fenders, modern single, double, and triple cranksets, as well as cantilever and linear-pull brakes. Yep, with a little tinkering, it's single-speedable, too, for you fellow one-speed freaks needing a 700c fix. We've given the frame a fresh new bean-green paint job, and we switched to a 1-1/8" threadless headset. Not because we think it's better system, but because of the much greater stem selection available, and because versatility and the ability to customize your ride with commonly available parts is a major cornerstone of the Surly™ design philosophy. Speaking of custom fit, the Cross-Check™ is available in TEN sizes, from 42-60cm, to fit riders large and small, and really small. More Cross-Check™ features you'll dig:

- **Tubing:** 100% cro-moly steel. Main triangle features double-buttet Reynolds™ 631 tubes. TIG welded.
- **Rear Dropouts:** Long horizontal dropouts with adjusters feature single-speed compatibility, wheelbase adjustability and our exclusive Gnot-rite™ 132.5mm spacing to easily fit 130mm road or 135mm MTB hubs, should you want to switch wheels between bikes and whatnot.
- **Tire Clearance:** We already said it, but our proprietary FFF™ (Fatties Fit Fine) chainstays and our custom fork give room for tires up to 700x45c with mud and fender clearance left over. Seriously!
- **Chainring Clearance:** Though we haven't yet tried a '56', we manipulated the chainstays heavily so you can fit whatever size rings you want, so go for it!
- **Downtube cable routing:** Simply put, top-tube routed shifter cables aren't any better, and they look crummy. Our downtube routed cables look clean, and don't promote water dribblin' down the rear derailleur cable.

We could go on and on, but we'll get to the point: **\$895.00** (higher in some areas) will get you a really sweet 'cross bike that is affordable, fun to ride, and built to last a long time. Once a competent, independent bicycle dealer assembles and preps your bike, you'll be trailbound and unable to wipe the grin off your face. Let us know how it goes...



Geometry:

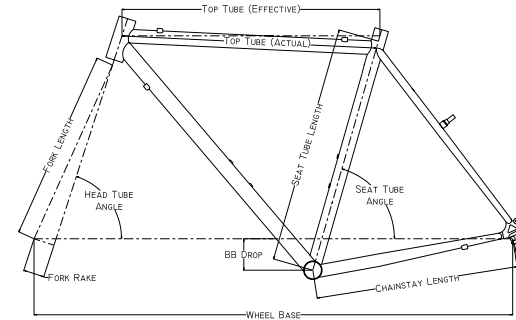

See next page for a complete Cross x Check frame geometry grid.

Component Sizing:

Size	Stem Length inches mm	Stem Angle** degrees	Bar Width inches mm	Crank Length inches mm
42 cm	2.0 50.0	84.0	15.7 400.0	6.7 170.0
44 cm	2.0 50.0	84.0	15.7 400.0	6.7 170.0
46 cm	3.1 80.0	84.0	15.7 400.0	6.7 170.0
48 cm	3.1 80.0	84.0	16.5 420.0	6.7 170.0
50 cm	3.1 80.0	84.0	16.5 420.0	6.7 170.0
52 cm	4.1 105.0	96.0	16.5 420.0	6.7 170.0
54 cm	4.1 105.0	96.0	17.3 440.0	6.9 175.0
56 cm	4.1 105.0	96.0	17.3 440.0	6.9 175.0
58 cm	4.7 120.0	96.0	17.3 440.0	6.9 175.0
60 cm	4.7 120.0	96.0	18.1 460.0	6.9 175.0

** Stems can be flip-flopped to customize angle.

Bike Specifications:

Component	Type	Description
Frame	Surly Cross-Check	100% cro-moly, double-buttet Reynolds 631 front triangle. TIG Welded. Bean-Green.
Fork	Surly Cross-Check	100% cro-moly, lugged + brazed crown. 1-1/8" threadless steerer. Bean-Green.
Headset	Ritchey Logic Comp	1-1/8" threadless, w/ 15mm spacers. Black.
Stem	Tahoma	1-1/8" threadless. Forged. Black.
Handlebars	Salsa Moto Ace Bell-Lap	26.0mm clamp diameter. Black.
Handlebar Wrap	Co-Union Cork Mix	Feels good. Black.
Brake Levers	Shimano	#BLR-400 aero.
Brakes	Tektro Cantilevers	#862A. Silver.
Cable Hanger, front	Tektro	#1271A. Includes routing noodle. Black.
Cable Hanger, rear	Dia-Compe	#1266. Silver.
Shift Levers	Shimano Bar-end type	#SL-BS77. 9-speed.
Shift Cable Adjusters	Jagwire	#CC-233 Microadjuster.
Front Derailleur	Shimano Tiagra	#FD-4403 Triple.
Rear Derailleur	Shimano Tiagra	#RD-4400-GS Mid-cage.
Crankarms	Cyclone	110mm BCD. Silver.
Chainrings	QBP Engagement Rings	36 x 48t.
Pedals	NOT INCLUDED	NOT INCLUDED
Bottom Bracket	Shimano Deore LX	#BB-UN52 68x113mm.
Seatpost	Kalloy Uno	27.2x250mm. Black.
Seatpost Clamp	Kalloy	Black.
Saddle	Velo Endzone	Steel rails, vinyl cover. Black.
Cassette	Shimano Tiagra	#HG-50 9-speed 12-13-14-15-17-19-21-23-25T.
Chain	Shimano HG-72	9-speed compatible.
Hubs	Shimano Deore	#HU-M510. 32 hole. 100mm O.L.D. front, 135mm O.L.D. rear. Black.
Spokes	Stainless Steel	Straight-gauge 15 w/ brass nipples.
Rims	Alex	#AL-DV15. 32 hole x 700c. Silver.
Tires	Ritchey SpeedMax Cross	700x32c. Wire bead. Black wall.
Tubes	Cheng Shin	Standard presta valve 700x35c.

Extras: Clear chainstay protector. Die-extruded cables with anti-rattle donuts. Full CPSC reflector kit. Generic owner's manual

Cross-Check™ Frameset

In 1999 we sold every Cross-Check™ cyclo-cross frameset we could make — and you let us know you like ‘em, you really like ‘em! We didn’t want to mess with a good thing, so this year we have made just three small changes to the Cross-Check™. We switched to a 1-1/8" headtube and fork, gave it a spunky new bean-green paintjob, and most importantly, we’ve upped our production to make sure y’all who want one get one.



Having made only these minor changes to the second-generation Cross-Check™, we once again bow in honor and respect to the rich European tradition of cyclo-cross racing, but leave the overpriced, single-purpose, disposably-light, short and twitchy framesets lacking of tire clearance to be made by some other manufacturer. When you spend your hard-earned cash on a Cross-Check™, you’ll get a very aggressive, multi-purpose, off-road worthy 700c-wheeled bike that is cross-raceable, rideable, tour-able, commute-able, and downright single-trackable. By now you know **there is no free lunch**, but once you ride a Cross-Check™ you’ll realize that it is possible to have a reasonable compromise between hard-core geometry and comfort, between weight and durability, and between price, features and quality.

We went to great lengths to ensure maximum compatibility with all available tire widths, brands of fenders, modern single, double, and triple cranksets, as well as cantilever and linear-pull brakes. Yep, it’s single-speedable right of the box, too, for you fellow one-speed freaks needing a 700c fix. We switched to a 1-1/8" threadless headset not because we think it’s a better system, but because of the much greater stem selection available, and because versatility and the ability to customize your ride with commonly available parts is a major cornerstone of the Surly™ design philosophy. Speaking of custom fit, the Cross-Check™ is available in TEN sizes, from 42-60cm, to fit riders large and small, and really small. Shrimps everywhere rejoice!

All this can be yours for the meager suggested retail of **\$399.00**, so you’ll have plenty o’ zhing left over for the after-ride activities, or, perhaps, another Surly™ for your stable. That price is up by twenty from last year, but if you ask around you’ll find that the Surly Cross-Check™ is a fantastic ride at twice that price.

Size	ST (C-T)		TT (C-G)		TT (Effec.)		HT Angle degrees	ST Angle degrees	BB Drop		CS Length	
	inches	mm	inches	mm	inches	mm			inches	mm	inches	mm
42 cm	16.5	420.0	19.9	505.0	20.6	522.0	72.0	75.0	2.6	66.0	16.5	420.0
44 cm	17.3	440.0	19.9	505.0	20.5	520.4	72.0	75.0	2.6	66.0	16.5	420.0
46 cm	18.1	460.0	20.3	515.0	20.8	528.8	72.0	74.5	2.6	66.0	16.5	420.0
48 cm	18.9	480.0	20.7	525.0	21.1	535.4	72.0	74.5	2.6	66.0	16.5	420.0
50 cm	19.7	500.0	21.1	535.0	21.3	541.8	72.0	74.0	2.6	66.0	16.5	420.0
52 cm	20.5	520.0	21.5	545.0	21.5	547.1	72.0	73.5	2.6	66.0	16.5	420.0
54 cm	21.3	540.0	22.0	560.0	22.0	560.0	72.0	73.0	2.6	66.0	16.5	420.0
56 cm	22.0	560.0	22.4	570.0	22.4	570.0	72.0	72.5	2.6	66.0	16.5	420.0
58 cm	22.8	580.0	22.8	580.0	22.8	580.0	72.0	72.5	2.6	66.0	16.5	420.0
60 cm	23.6	600.0	23.6	600.0	23.6	600.0	72.0	72.0	2.6	66.0	16.5	420.0

Specifications:

Tubing: 100% cro-moly steel. Main triangle features double-buttet Reynolds™ 631 tubes. TIG welded.

Rear Dropouts: Long horizontal dropouts with adjusters feature single-speed compatibility, wheelbase adjustability and our exclusive Gnot-rite™ 132.5mm spacing to easily fit 130mm road or 135mm MTB hubs.

Braze-ons: Cantilever bosses front and rear, fender eyelets front and rear, and dual water-bottle mounts. Down tube shift cable routing.

Seatpost diameter: 27.2mm.

Seatpost clamp diameter: 30.0mm.

Headset: 1-1/8" threadless.

Bottom bracket shell: 68mm wide, threaded English 1.37x24t.

Tire Clearance: Proprietary FFF™ (Fatties Fit Fine) chainstays and our custom fork give room for tires up to 700x45c with mud and fender clearance left over. Seriously!

Chainring Clearance: Though we haven’t yet tried a ‘56’, we manipulated the chainstays heavily so you can fit whatever size rings you want, so go for it!

Color: Bean Green

Geometry:

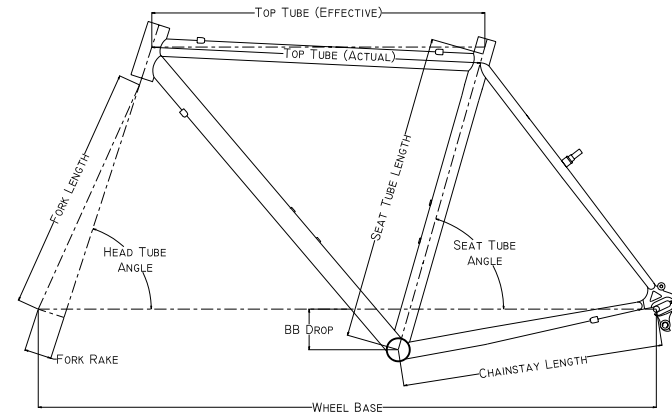

Size	Wheel Base		S.O. Height*		HT Length		FK Length		FK Rake	
	inches	mm	inches	mm	inches	mm	inches	mm	inches	mm
42 cm	39.0	989.9	28.8	731.9	3.6	91.0	15.7	400.0	1.7	44.0
44 cm	38.9	988.2	29.2	741.6	3.6	91.0	15.7	400.0	1.7	44.0
46 cm	39.1	991.9	29.6	750.7	3.6	91.0	15.7	400.0	1.7	44.0
48 cm	39.3	998.5	29.9	760.4	3.6	91.0	15.7	400.0	1.7	44.0
50 cm	39.6	1005.3	30.3	769.4	3.6	91.0	15.7	400.0	1.7	44.0
52 cm	39.6	1006.0	30.6	778.4	3.6	91.0	15.7	400.0	1.7	44.0
54 cm	39.9	1014.4	31.2	793.0	4.0	102.0	15.7	400.0	1.7	44.0
56 cm	40.1	1019.8	31.9	810.7	4.8	121.0	15.7	400.0	1.7	44.0
58 cm	40.6	1030.0	32.7	829.9	5.6	141.0	15.7	400.0	1.7	44.0
60 cm	41.1	1044.8	33.4	847.4	6.3	160.0	15.7	400.0	1.7	44.0

*Measurements use tire with 685 mm outer diameter (Ritchey™ 700c x 30 SpeedMax™), and taken from middle of top-tube to level ground.

New! Steamroller™ Frameset

A steamroller has the ability to flatten anything in its path, which is exactly how you'll feel the first time you take our new Surly Steamroller™ fixed-gear for a twirl. Unstoppable. Euphoric. Happy. If you haven't ridden 'fixed' before you might even feel a little bit scared.



Designed specifically to give you the ideal foundation for a pure and unadulterated fixed-gear bicycle, some will see the Steamroller™ and think “messenger”, while others will automatically think “track”. We hope you'll think about those two, plus “coffee shop”, “watering hole”, “commuter”, “urban assault”, “double century” and whatever else. What you do with it is up to you, we can only hope you won't let your preconceived notions about fixed-gear bikes impair your ability to realize the possibilities of the Steamroller™ frame. The only thing it wasn't designed to do is **coast**, although if you decide to strap a coaster brake out back, we won't spoil your plans. Do what you like, because as with all Surly™ products, this frameset is merely another platform to expand your horizons and bring your rides to a new or different level of enjoyment.

Since reliable freewheeling technology evolved decades ago, folks have ridden fixed gears by choice, not out of necessity. We won't try to convince you that riding 'fixed' is better or special or why you should try it, you'll have to determine that for yourself. We will take the opportunity to say that at the unbelievably low price of **\$379.00** for frame and fork, this may be the best chance you've had yet to give coast-free riding a shot. Gee, the Steamroller™ just might change your life (if this happens please call us)!

The Steamroller™ geometry, tubing choices and features or lack thereof are deliberate in our quest to bring you a balance of pure aesthetics and a ride that is aggressive enough to be quick, exciting and purposeful, yet just mellow enough to be ridden all day long in comfort. We gotta point out the nice fork crown, its even drilled for a long-reach safety brake, should you opt for one.

The Steamroller™ is available in 4 sizes to fit a spectrum of riders, and was designed by fixed-gear riders for fixed-gear riders. We also have some other fine 4130 offerings and neat parts... take a look!

Size	ST (C-T)		TT (C-C)		TT (Effec.)		HT Angle		ST Angle		BB Drop		CS Length	
	inches	mm	inches	mm	inches	mm	degrees	degrees	inches	mm	inches	mm	inches	mm
49 cm	19.3	490.0	20.7	526.5	20.8	529.5	72.5	74.5	2.8	70.0	15.7	398.0		
53 cm	20.9	530.0	21.5	547.0	21.5	547.0	73.0	74.0	2.8	70.0	15.7	398.0		
56 cm	22.0	560.0	22.4	568.0	22.4	568.0	73.5	73.5	2.8	70.0	15.7	398.0		
59 cm	23.2	590.0	23.1	587.0	23.1	587.0	74.0	73.0	2.8	70.0	15.7	398.0		

Specifications:

Tubing: 100% cro-moly steel. Main triangle is double-buttet. TIG welded.

Rear Dropouts: Investment cast “Sub 11.0” track dropouts, spaced 120mm apart.

Braze-ons: None, baby. Pure. OK, we put one set of water-bottle mounts on the seat tube 'cause we're not camels.

Seatpost Diameter: 27.2mm.

Seatpost Clamp Diameter: 30.0mm.

Headset: 1" threaded English standard 30.2 cups / 26.4mm crown

Bottom Bracket Shell: 68mm wide, threaded English 1.37x24t

Tire Clearance: Proprietary FFF™ (Fatties Fit Fine) chainstays and our custom fork give room for tires up to 700x38c with fender clearance left over (P.S. - use clip-on fenders!!)

Chaining Clearance: Heavy manipulation of the FFF™ stay gives room for any size ring you wanna use while maintaining chainline.

Color: Boston Baked Bean

Geometry:

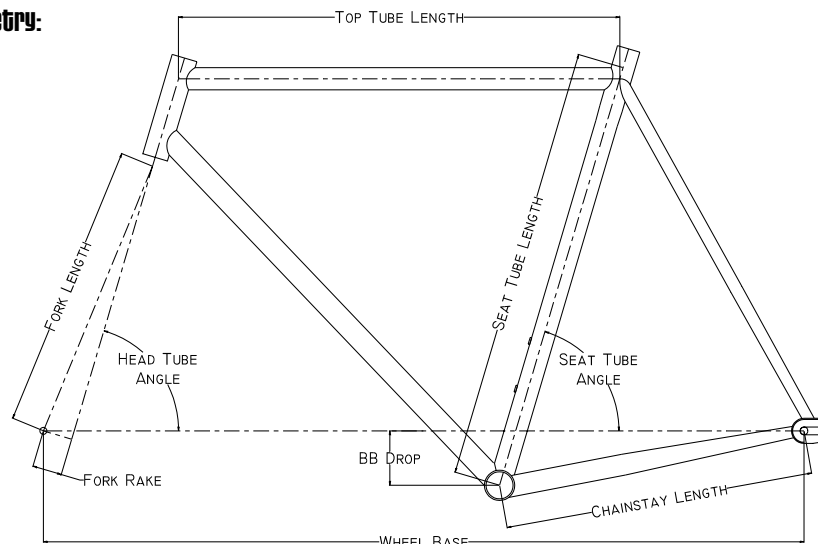

Size	Wheel Base		S.O. Height*		HT Length		FK Length		FK Rake	
	inches	mm	inches	mm	inches	mm	inches	mm	inches	mm
49 cm	38.0	965.7	29.5	748.5	3.1	80.0	14.5	368.0	1.5	38.0
53 cm	38.1	966.6	30.7	780.5	4.2	106.0	14.5	368.0	1.5	38.0
56 cm	38.5	978.6	31.8	807.9	5.2	133.0	14.5	368.0	1.5	38.0
59 cm	38.9	987.6	32.9	835.2	6.3	160.0	14.5	368.0	1.5	38.0

* Measurements use tire with outer diameter of 682 (700c x 28), and taken from middle of top-tube to level ground.

1x1™ Frameset



Nobody wants to spend a bunch of cash on a single-speed... and why should they? To do so is contrary to the whole spirit of the single-speed experience. At Surly, we have recognized this for years and are continuing to offer our excellent 1x1™ single-speed frameset. Unchanged since its inception, the 1x1™ features a beefy, double-butted 100% Cro-Moly suspension-corrected frame and 1-1/8" hard fork with very nice black powdercoating and cool white decals. As if there were any doubt, the one-speed bandwagon has already left town, folks, and the 1x1™ is here to stay.

All hype aside, the motivations to purchase a 1x1™ are endless. Maybe you need a derby-rated steed to steamroll some 700c's. Maybe your financial sensibilities have kicked into overdrive at the sight of thick 4130 steel for a price you can justify. Perhaps the wide, curvy stays tempt you to try stuffing in some flat-trackin' skins. Maybe you can't stomach the extra twelve cents per gallon for premium, or maybe you just wanna try something new. Whatever the reason, we're sure you will appreciate the form, function and value of the 1x1™ as much as we do.

How does it ride? Take a look at our detailed geometry chart and you'll see our design is, well, regular. Take the 1x1™ for a spin and you'll find that it merely "rides like a bike" - leaving you right at home to forget about the machine and enjoy the ride. The 1x1™ rides so nice you won't notice it, you 1x1™ owners who have written know what I'm talkin' about. Fantastic at any price if we may say, though at a suggested retail of **\$359**, you won't be able to wipe the smile off your face.

The 1x1™ is available in small, medium, large, and suddenly now XL sizes. Designed by single-speeders for single-speeders, and as with all things Surly™, you can't go wrong. Keep lookin' our way for more good deals on tough cro-moly bikes, framesets and unique components.

Size	ST (C-T)		TT (G-G)		TT (Effec.)		HT Angle	ST Angle	BB Drop		CS Length	
	inches	mm	inches	mm	inches	mm	degrees	degrees	inches	mm	inches	mm
small	16.0	406.4	20.8	528.1	21.7	550.0	71.0	73.0	1.7	42.5	16.5	419.0
medium	18.0	457.2	22.4	567.7	23.0	585.0	71.0	73.0	1.7	42.5	16.5	419.0
large	20.0	508.0	23.2	588.2	23.6	600.0	71.0	73.0	1.7	42.5	16.5	419.0
x-large	22.0	558.8	24.2	615.0	24.2	615.0	71.0	73.0	1.7	42.5	16.5	419.0

Specifications:

Tubing: 100% cro-moly steel. Main triangle is double-butted. TIG welded.

Rear Dropouts: Investment cast "Sub 11.0" track dropouts, spaced 135mm apart.

Braze-ons: Cantilever bosses front and rear, fender eyelets front and rear, and dual water-bottle mounts.

Seatpost Diameter: 27.2mm.

Seatpost Clamp Diameter: 30.0mm.

Headset: 1-1/8" threadless standard

Bottom Bracket Shell: 73mm wide, threaded English 1.37x24t

Tire Clearance: Proprietary FFF™ (Fatties Fit Fine) chainstays and our custom fork give room for tires up to 2.7" with plenty of mud and fender clearance left over. Seriously!

Fork: Suspension corrected for 3" travel sus fork. 100% cro-moly.

Color: Black

Geometry:

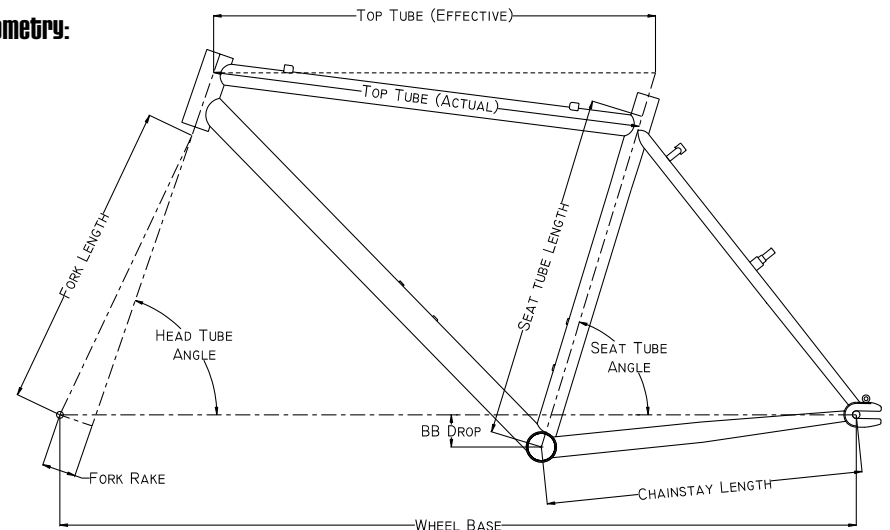

Size	Wheel Base		S.O. Height*		HT Length		FK Length		FK Rake	
	inches	mm	inches	mm	inches	mm	inches	mm	inches	mm
small	40.1	1018.5	29.0	736.6	3.5	89.0	16.6	421.0	1.8	45.0
medium	41.5	1053.9	30.2	768.2	4.0	102.0	16.6	421.0	1.8	45.0
large	42.0	1066.5	31.4	797.6	4.5	114.0	16.6	421.0	1.8	45.0
x-large	42.7	1084.9	32.7	830.0	5.3	134.0	16.6	421.0	1.8	45.0

* Measurements use tire with diameter of 676 mm (Tioga™ 2.1 DH), and taken from middle of top-tube to level ground.

The Singleator mounts to your derailleur hanger and provides a simple, effective, adjustable means of tensioning excess chain slack found in vertical dropout single-speed drive trains.

Singleator Features : triple sealed reversible spring, 22t cog capacity, chain-rejection protection, fully adjustable chain line, floating tension pulley, and a stainless steel pivot bushing. Stop being so damn serious— get yourself a Singleator, and give the single lifestyle a try.

Colors: Black or Silver.

MSRP: \$50

The 1x1 Speed Gear Chart

1x1	24	26	28	29	30	31	32	34	36
16	1.50	1.63	1.75	1.81	1.88	1.94	2.00	2.13	2.25
17	1.41	1.53	1.65	1.71	1.76	1.82	1.88	2.00	2.12
18	1.34	1.45	1.56	1.61	1.66	1.72	1.78	1.89	2.00
20	1.20	1.30	1.40	1.45	1.50	1.55	1.60	1.70	1.80
22	1.09	1.18	1.27	1.32	1.36	1.41	1.45	1.55	1.64

When the bandwagon rolls through your town, be ready with the 1x1^a single-speed hubs. You'll be confident in your derby abilities rolling on this pair of rugged hubs. The 1x1^a single-speed hubs are forged and CNC-machined from 6061 aluminum and feature 4130 Cro-Mo solid axles, spinning on sealed cartridge bearings. The 135mm-spaced rear hub allows the use of BMX freewheels and as an added bonus, it's threaded on each side for the convenience of quick gear changes. The front hub is 100mm spaced, and the matched pair is available in black or silver. (32) Both feature the handsome 1x1^a laser-etched logo.

Color: Black or Silver

MSRP: \$45 (front) \$54 (rear)

Made for us by NITTO™, these wide, flat, 4130 Cro-Mo bruisers will give you a distinct advantage in any derby situation. With a 15° bend, and 24.5" width, they're mighty comfortable in that laid-back single way. Get ready to flat track!

Color: Silver

MSRP: \$35



The 1x1 Blowerdrive^a is a one-piece chainring spider and trials-style bashguard that mounts directly onto Shimano's popular Deore LX™ M569* and Deore XT™ M739* splined crankarms. This extremely durable and uniquely styled unit's coolest feature is its ability to fit 74mm, 94mm, or 110mm BCD chainrings --no more gear limitations due to poor freewheel selections, and no need to buy a bunch of new chainrings to experiment with strange gear combinations. We bet there's stuff hanging on your bench that will bolt right on. The Blowerdrive's integrated bashguard is geared for extra grip when bushwhacker mode is on, and will protect chainrings up to 36 teeth. Blowerdrives include chainring hardware and look pretty tough, as well.

*The Blowerdrive^a WILL NOT work with any other cranks!

Colors: Black or Silver

MSRP: \$50